

# PDY126F

SELF PROPELLED MAST PLATFORMS

## STANDARD FEATURES

### Performance

- Easy Onboard Calibration®
- Fly Boom
- 350° Turret Rotation
- Drive at Height
- Drive speed proportional to height
- Speed / Torque Drive Selection
- Hydromotors with brake
- Drive Traction Control System
- 20% Gradability
- Proportional Joystick Controller
- Customizable Descend Speed
- Digital Control Panel
- Aluminium Basket
- Non marking Grey Tires
- Orange - White Paint
- Hour Meter
- Lighting on Basket
- Horn

### Safety

- TS-EN 280 + A1 / CE Conformity
- Emergency Bypass® System
- Emergency Stop Buttons on Control Panels
- Pressure Holding and Interlocking Valves against Hose Blasts
- High Pressure Relief Valve
- Emergency Descend Hand Pump
- Descend Buzzer

## OPTIONAL FEATURES

- Basket Load Cell
- Basket Rotation
- 70000V Insulated Fiberglass Basket
- Steel Basket
- 110V / 220V / 380V Socket in Basket
- Basket Toolbox
- Anemometer on Basket
- Air Outlet on Basket
- Wireless Remote Controller
- Custom Paint Color
- Additional Lighting

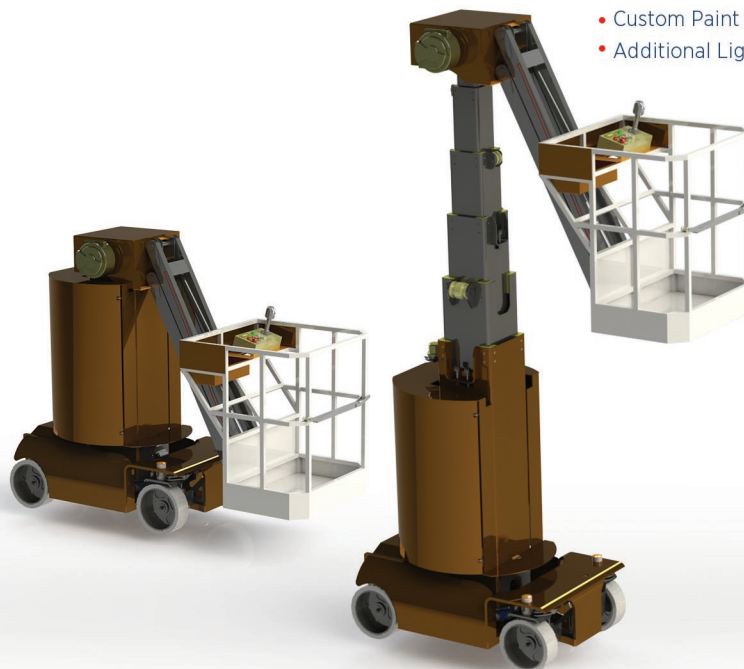

TECHNICAL DATA		PDY 126F
Operating Height		11,2 m
Platform Height		9,2 m
Lateral Outreach		3,2 m
Turret Rotation		350°
Basket Capacity (kg)		200 kg
Basket Dimensions		900 x 660 x 1100 mm
(A) Stowed Height		1990 mm
(B) Stowed Length		2690 mm
(C) Stowed Width		1000 mm
Control System		Electronic Proportional Joystick
Weight		3250 kg
Batteries		245 Ah / 12V DC 6Vx4
Battery Charger		40Ah
Drive System		Hydromotor

